

- > RAINSTAR A
- > RAINSTAR T
- > RAINSTAR E



# RAINSTAR

THE „STARS“ AMONG THE SPRINKLERS



# RAINSTAR HISTORY

**Leader in technology for decades  
and No. 1 on the world market.**

**Growth through efficient irrigation.**

Nearly 40 years ago, BAUER revolutionised the world of irrigation with the drum system. Since then a lot has happened. We have not been resting on our laurels but continuously developed the BAUER-system further.

By innovations, e.g. the introduction of the turbine technology, our own gearboxes and turbine production we were able to further extend our lead. From decades of field experience new technologies emerged and from them the new BAUER Rainstar family.



# RAINSTAR PRODUCT OVERVIEW

The advantages of the different models speak for themselves.

- BAUER RAINSTAR – a range of models designed to accommodate any size and shape of farming system
- Cost and energy saving irrigation – user-friendly – optimum performance and reliability
- Quality workmanship – decades of experience in the manufacture of irrigation machines – particularly attractive price-performance ratio
- Laser-machined precision-toothed chain sprockets ensure precise chain drive and high reliability
- Pipe reel and steelwork fully hot galvanised – high quality corrosion protection ensures lasting value and high resale value
- Modern design – central control, easily accessible unit with irrigation computer
- New radial full flow turbine – cost and energy saving irrigation, particularly efficient when low precipitation rates are applied
- Raingun trolley with automatic angle compensator for uneven ground and trolley inlet
- The RAINSTAR E55 completes the 11 RAINSTAR models offered with over 80 different pipe lengths

**RAINSTAR T**  
THE  
UNIVERSAL  
ONE



**RAINSTAR E**  
THE  
PROFESSIONAL  
ONE



**RAINSTAR A**  
THE  
COMPACT  
ONE



# RAINSTAR A

## The compact series in a modern design

Easy handling, optimal output and innovative technology make the new A-Series irrigation machines from BAUER ideal for a wide variety of applications such as Sports facilities, parkland, schools, golf courses, garden centers, cemeteries, etc.

The same philosophy of quality, technology, and precision applied to our larger Rainstar units used in agriculture can also be found in the A-Series models.

Highest value due to an extraordinary price-performance ratio, best irrigation efficiency and wide range of applications.

Quick and easy swiveling of the reel into its required working position is easily done by only one person due to a 3-wheel chassis and automatic gun trolley lift.

RAINSTAR  
A2



### Compact Drive Unit

The compact drive unit includes the BAUER full-flow turbine, the V-belt transmission and speed change gearbox.

This unit offers the optimum in economy and operating efficiency. Power transmission to the pipe reel is via a strong high-quality chain and precision laser-cut toothed gear elements. This optimised design offers extremely low pressure loss and high efficiency power output.

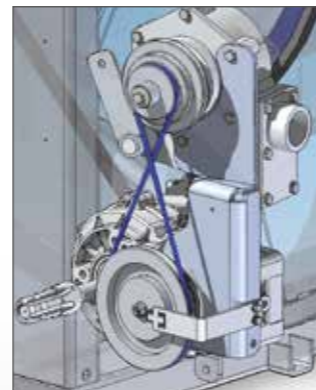

### New pump generation

Powerful, compact BAUER turbine/gear box combination for RAINSTAR A1 and A2 with precise adjustment and exchangeable nozzles for high efficiency.

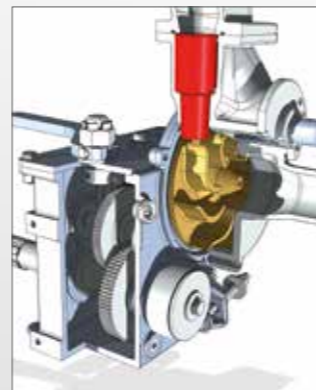

### RAINSTAR A1 AND A2 – THE SMALL ONE

- Hot-dip galvanizing for reel and frame
- Drive with new BAUER turbine-gear-combination
- PTO-reel equipment
- Automatic cart load
- BAUER special-PE-pipe



### Largest model in the A-Series is a true Irrigation Specialist

Pro-gardening, Parkland, horticulture, golf courses, sports facilities and model farms – the RAINSTAR A3 multi-tasks in most applications – a smart choice for irrigation.

- RAINSTAR A3 with BAUER specific PE-pipe, Hot-galvanized pipe reel, turntable and chassis
- Two-wheel gun-trolley with wide-profile tyres. Adapts easily to any crop row spacing. The chassis has a rotating pipe reel and integrated leg supports
- Drive system is BAUER full-flow turbine
- 3 Speed adjustable V-belt transmission
- Mechanical speed regulator with automatic pipe layering compensator
- Speed-change gearbox with PTO winding system
- Power transmission is via precision chain drive
- Automatic gun-trolley lift
- Automatic final shut-off device
- PE-pipe rewind system with precision rewind shaft and strong support chassis
- Single axle chassis with universal variable track width ranging from 1000 – 1500 mm



# RAINSTAR T

## The compact series for cost saving irrigation

### Advantages

- Revolving pipe reel – with integrated hydraulic leg supports
- 2 wheel chassis with adjustable track width and mechanical jack
- Energy saving BAUER full flow turbine TVR 20 (T51 – T61) with BAUER 4-speed gearbox
- Newly developed turbine TVR 18 (T32 – T42) with BAUER 4-speed gearbox
- Irrigation computer ECOSTAR 4300 with back up battery and solar panel for exact precipitation rates and high performance and reliability
- User friendly – hydraulic jack, unit connection on both sides, central control unit, hydraulic gun trolley lift (together with supports)
- Gun trolley with automatic angle compensation – keeps the Rainer in an ideal position, on uneven rough ground
- Special BAUER PE-pipe – High form stability and tensile strength

Cost efficient irrigation by saving energy, convenient, time saving handling and operational safety even at extreme stress are only a few of the many advantages of this generation of machines.

The RAINSTAR T with the new TVR-radial full flow turbine is available with an ECOSTAR irrigation computer

No matter which field size or form, the innovative modular design of the RAINSTAR T easily adapts to every condition and offers tailor made equipment for every irrigation process.

The particularly attractive price-performance ratio guarantees in the first place the cost effectiveness of your purchase for the next irrigation season.



**RAINSTAR T61**

**RAINSTAR T32**

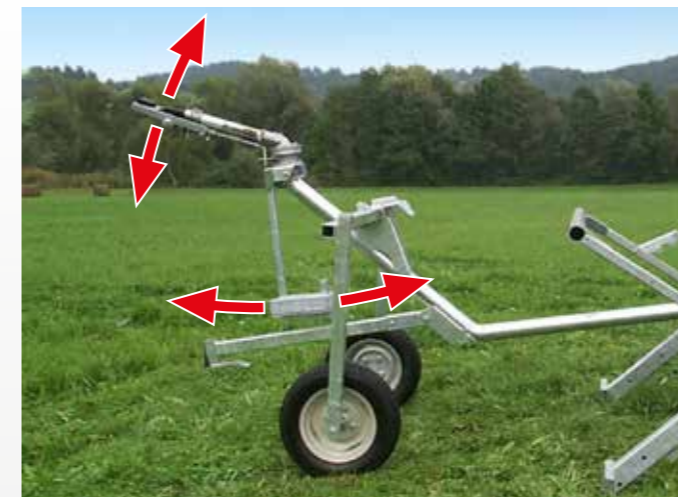

### Combi-wheel cart gentle to the crops

The multi talent among the carts: infinitely adjustable track, symmetric or asymmetric PE-pipe retraction (simple retrofitting), large clearance height. This reduces damage even with tall growing plants. The large dimensioned tires guarantee a safe irrigation process, even in difficult terrain.



### Boom cart AS 26 / AS 32

Irrigating with a boom cart guarantees a precipitation which is very gentle to all crops and plants. Even a very low connection pressure is sufficient for operation. This means efficient use of energy and water. The boom cart made of steel and aluminum parts convinces with high stability despite its light weight construction.

# RAINSTAR E

The high-quality series – a continuing success

### Advantages

- Revolving pipe reel with integrated hydraulic leg supports
- 2 wheel chassis with adjustable track width and mechanical jack
- Energy saving BAUER full flow turbine TVR 60
- Irrigation computer ECOSTAR 4300 with back up battery and solar panel for exact precipitation rates, high performance and reliability
- User friendly – hydraulic jack, HK108 unit connection on both sides, central command unit, hydraulic gun trolley lift (together with supports)
- BAUER 4-speed gearbox with brake and tractor PTO rewind
- Gun trolley with automatic slope compensation – keeps the raingun in an ideal position on uneven rough ground
- Special BAUER PE-pipe – high form stability and tensile strength



Reliability, durability and efficiency are the priorities regarding the requirements for an irrigation machine. With the RAINSTAR E models these requirements are not only met but even exceeded. This generation of RAINSTARS has a completely new design. The hot-dip galvanizing of the entire steel construction is a visual proof of the traditional BAUER-syntheses of technology, robustness, durability and design. The entire production is carried out in compliance with the highest quality standards in accordance to the ISO 9001 guidelines.



### Advantages of the RAINSTAR E51 XL

Chassis 4-wheel – either with 4W tandem swing axle and adjustable track width or with 4WB chassis with two rigid axles and fixed track



### Boom trolley AS 50

The AS 50 boom trolley matches exactly with RAINSTAR E models and applies a gentle precipitation mist on strip widths up to 72 m. Special weights continuously balance the boom parallel to the ground. An infinitely variable hydraulic height adjustment provides ground clearance from 1.3 m to 2.3 m (AS 50) ie: the system is also ideal for higher crops.



**RAINSTAR E41**



**RAINSTAR E51 XL**



### RAINSTAR with hydraulic drive

External drive with hydraulic motor for distribution of viscous liquids, such as sludge and slurry. Compact and user-friendly hydraulic unit offers precise precipitation control plus high retraction speeds.

# RAINSTAR E55 L & E55 XL

The professional series with high quality level

## Advantages

- Pipe reel can be lowered hydraulically and swivelled 360° – pull-out possible in each direction
- 4-wheel chassis with tandem swing axle for lower ground pressure and uniform weight distribution
- Separately controlled Hydraulic machine supports, adjust to uneven ground
- Energy saving BAUER full flow turbine TVR 60
- Irrigation computer ECOSTAR 4300 with back up battery and solar panel for exact precipitation rates, high performance and reliability
- User friendly – hydraulic jack, HK 108 unit connection on both sides, central command unit
- BAUER 4-speed gearbox with brake and tractor PTO rewind
- Raingun trolley with automatic slope compensation – keeps the sprinkler in an ideal position on uneven ground
- BAUER PE-pipe – high form stability and tensile strength



## Plant Protection

Despite the large 3.5 m diameter of the drum, the unit is very compact. The PE pipe is lowered hydraulically and the drum then pivots a full 360°. Thanks to minimal space requirements, the unit causes little damage to plants.

RAINSTAR  
E55 L  
E55 XL



## Firmly anchored to the ground

Strong, hydraulic supports anchor the unit to the ground. The overall construction is extremely strong and suited for retraction forces up to 40% stronger when compared to competitors similar offerings.



# RAINSTAR CONTROL

## Irrigation control on a high-tech level

- Easy operation at the push of one button
- A 4-line display with lighting shows the respective irrigation status
- Due to permanent target-performance comparison of the retraction speed the most exact precipitation rates are possible
- Programming of pre- and post-irrigation easy and comfortable at the push of a button
- A solar panel and a 12 volts battery provide adequate power supply
- Simple operation as well as clear menu navigation speak for themselves

### ECOSTAR 6000



#### Latest irrigation electronics for precise control of precipitation rates, as well as control and monitoring via SMS function.

- Powerful irrigation electronics with 4.3 „Full LED, Touch display
- Basic functions can be accessed via buttons as well as be selected via the display
- Program preselection of 12 different programs
- Recording of water consumption on different levels
- Switching of operation / programming of retraction speed to precipitation rate
- SMS-control and monitoring
- Signal for user if end of PE-pipe is reached
- Signal for operation of short distance sprinkler
- Record and if required read out the last operating steps for error analysis
- Automatic functional analysis of all components and sensors

### SMARTRAIN



#### Simple monitoring and control of different irrigation machines via App directly from the smartphone or the office on the PC.

- Permanent GSM-internet-communication between user and irrigation machine
- Monitoring and control of the irrigation process with smartphone, tablet or PC
- Clear, visual representation of the irrigation machines on the field
- Optimized irrigation process via entering different irrigation sectors with different precipitation rates
- Warning in case of errors and recording the cause of error
- Automatic evaluation and reports of operating hours wet/dry, water consumption and historical precipitation

### ECOSTAR 4300

#### High-tech irrigation control. Live check the operational status, plus start and stop the machine via SMS.

- |  |   |
|--|---|
| ▪ Easy operation at the push of one button | ▪ Real-time clock-start time indication |
| ▪ 4-line display                           | ▪ Operation-hour counter                |
| ▪ Irrigation status indication             | ▪ Variable irrigation speed zones       |
| ▪ Permanent set-actual speed comparison    | ▪ Precipitation indicator               |
| ▪ Solar panel +12V battery                 | ▪ Input and output for SMS control      |

#### SMS for ECOSTAR 4300

- Status information
- START and STOP of the machine
- Change of retraction speed
- Error messages

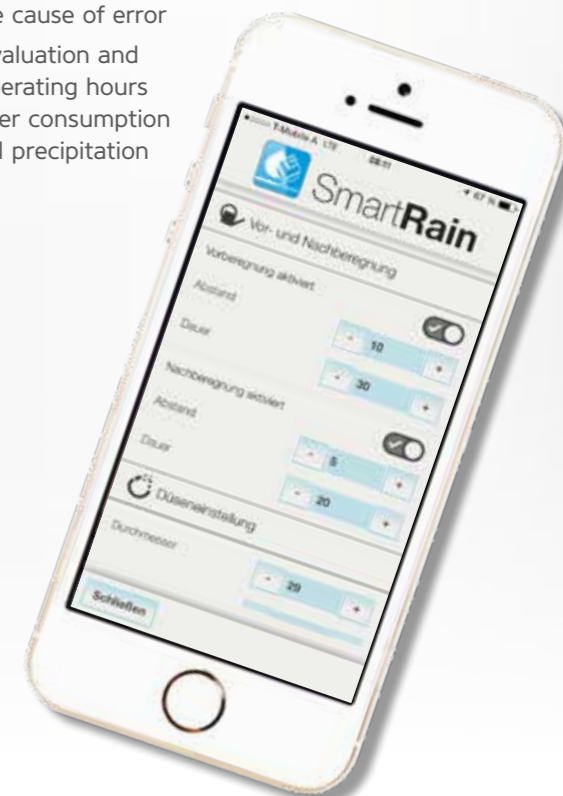



# RAINSTAR GEAR

**Power and economy in one drive unit**

## Turbine TVR 60 and TVR 20

The radial full-flow economy turbine TVR 60 (E models) and TVR 20 (T models) with the unique Vario nozzle is a power pack and energy saver in one. Extremely low pressure loss helps to save money, particularly when low precipitation & hence water-saving rates are applied.

Advantages – precise regulation plus broad performance range, even with high retraction speeds.



## Comparing efficiency levels

The extremely high efficiency level of the Bauer turbine, plus excess performance capacity & minimal pressure loss during normal range operation, ensures reliability and extensive savings under particularly difficult operating conditions ie: compared to turbines of competitors.

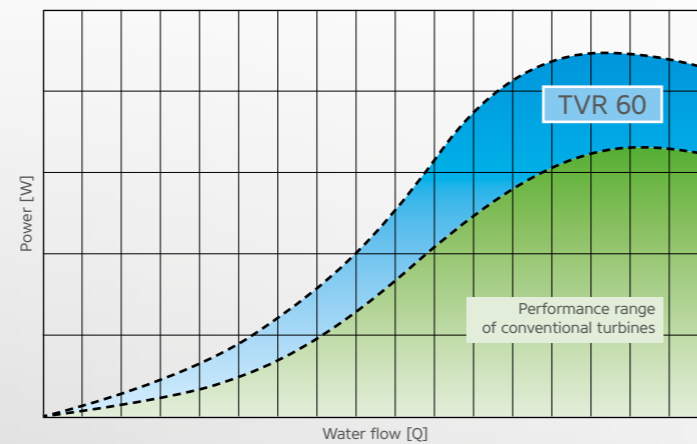

Pinpoint precision assembly results in the highest operating efficiency. Each individual part of the high-tech turbine is engineered in the headquarters at Voitsberg. The turbine is assembled by highly qualified technicians. Prior to being fitted to the Rainstar, the turbine's quality and performance are tested on a highly modern engine test bench.



## Cost savings thanks to highest efficiency

The drive train of the BAUER RAINSTAR is design optimised in every detail. This ensures highest efficiency, reliability and ease of operation.

A v-belt transfers the turbine's concentrated power without energy loss direct to the BAUER 4-speed gearbox. 4 different transmission gear ratios ensure the turbine operates at cost saving maximum efficiency.

The power required to rewind the PE-pipe onto the large-diameter pipe reel is transmitted via a high strength, high quality chain plus a laser-machined precision-toothed gear sprocket. The retraction power is evenly distributed over a large surface area, due to the expanded outer diameter of the chain wheel & higher density of gear-teeth sprockets.

At the end of the irrigated strip, the drive gear is disengaged automatically, and the power transmission is stopped. The aerated drum brake is placed directly on the drive & ensures highest security during road transport.

## Computer-controlled regulation

The regulation of the turbine is controlled electronically. The Vario nozzle keeps the retraction speed constant from the beginning to the end of the strip, with precise & optimum pressure utilisation.

## Vario nozzle

Maximum use of output is achieved by direct flow from the Vario nozzle onto the impeller. At maximum and minimum nozzle settings, the full stream flows over the turbine's impeller. This ensures the highest efficiency and minimum pressure loss at all flow rates.

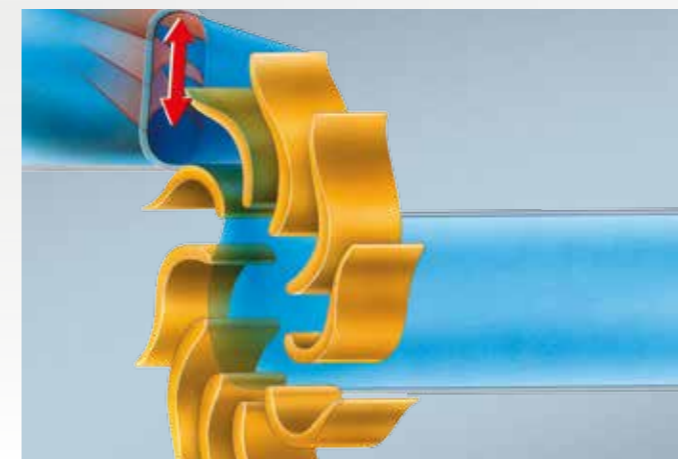

Comfortable gear changes with precise shift gate and indication of the gear selected. Safe and simple gear-shift.

The safety lock on the clutch lever prevents changing gear while the drive is engaged.

**Safety has priority!**

Certified engine production standards, following the highest quality requirements for high durability and maximum reliability.

# RAINSTAR FEATURES

Convincing arguments for  
successful irrigation

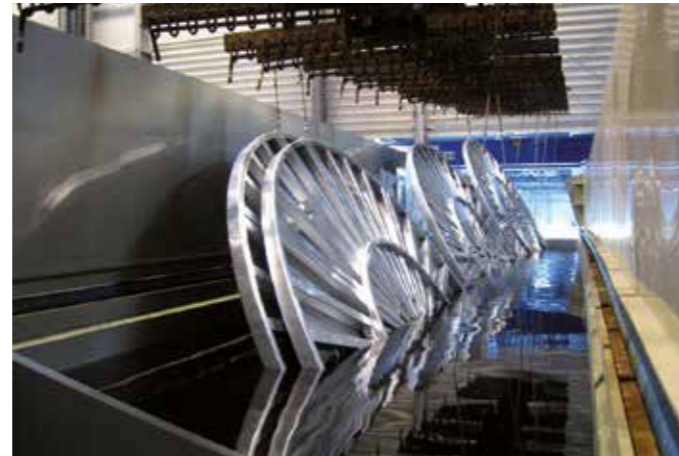

### Galvanisation

Hot dip galvanising to pipe drum, turntable and undercarriage.



### PE-pipe manufacture

In house PE-pipe production with special granulate material for highest strength & quality.



### Blow out device

The PE-pipe is exhausted via an original BAUER compressor and ball matching the pipe diameter.



### Fully rolled inner reel drum

The inner reel drum of each RAINSTAR is fully closed and equipped with a pipe guiding device.



### Winding gear

The PE pipe is gently layered by a double guided winding mechanism & precisely driven by a helically grooved spindle.



### Brake (optional)

For safe road transport, a compressed air brake can also be installed on the Rainstar as an option.

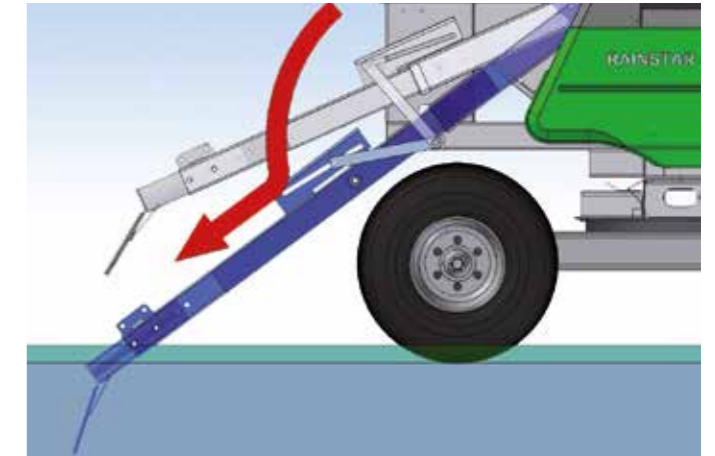

### Sturdy machine supports

The specific kinematics and the flat angle of the hydraulic unit supports direct the forces into the machine's centre.



### Precision chain drive

Precision-manufactured drive sprocket for the reel drive ensure even distribution of forces on a large surface area.



### Lighting (optional)

In addition, a lighting can be ordered for better visibility of the machines in traffic.

**RAINSTAR A**
**Specification**

| RAINSTAR Model | Type     | PE-pipe Ø mm | PE-pipe Length m | Strip width m | Consumption m³/h | Nozzle sizes mm | Connection press bar | Weight kg  |            |
|----------------|----------|--------------|------------------|---------------|------------------|-----------------|----------------------|------------|------------|
|                |          |              |                  |               |                  |                 |                      | with water | less water |
| <b>A1</b>      | 40 - 135 | 40           | 135              | 28 - 38       | 3,0 - 7          | 7 - 10          | 3,2 - 8              | 389        | 269        |
|                | 43 - 125 | 43           | 125              | 30 - 50       | 4,0 - 10         | 7 - 12          | 3,2 - 8              | 393        | 268        |
| <b>A2</b>      | 50 - 135 | 50           | 135              | 28 - 54       | 3,2 - 13         | 7 - 14          | 3,2 - 8              | 526        | 341        |
|                | 55 - 120 | 55           | 120              | 30 - 58       | 4,0 - 16         | 8 - 16          | 3,2 - 8              | 546        | 351        |
|                | 58 - 115 | 58           | 115              | 32 - 62       | 5,0 - 20         | 9 - 16          | 3,2 - 8              | 568        | 353        |
| <b>A3</b>      | 55 - 170 | 55           | 170              | 38 - 57       | 7,5 - 18         | 10 - 16         | 4,0 - 8              | 792        | 515        |
|                | 63 - 125 | 63           | 125              | 38 - 62       | 7,5 - 20         | 10 - 16         | 4,0 - 8              | 778        | 512        |
|                | 63 - 150 | 63           | 150              | 38 - 62       | 7,5 - 20         | 10 - 16         | 4,0 - 8              | 855        | 537        |

**Dimensions**

| RAINSTAR Model | A mm  | B mm  | C mm  | D mm  | E mm          |
|----------------|-------|-------|-------|-------|---------------|
| <b>A1</b>      | 3.220 | 1.230 | 1.490 | 1.240 | 1.000 - 1.500 |
| <b>A2</b>      | 3.420 | 1.480 | 1.490 | 1.240 | 1.000 - 1.500 |
| <b>A3</b>      | 3.550 | 1.690 | 1.730 | 1.250 | 1.000 - 1.500 |

**RAINSTAR T**
**Specification**

| RAINSTAR Model | Type      | PE-pipe Ø mm | PE-pipe Length m | Strip width m | Consumption m³/h | Nozzle sizes mm | Connection press bar | Weight kg  |            |
|----------------|-----------|--------------|------------------|---------------|------------------|-----------------|----------------------|------------|------------|
|                |           |              |                  |               |                  |                 |                      | with water | less water |
| <b>T32</b>     | 65 - 270  | 65           | 270              | 53 - 68       | 14 - 35          | 14,0 - 22,0     | 3,5 - 11,0           | 2.060      | 1.407      |
|                | 65 - 320  | 65           | 320              | 53 - 68       | 14 - 35          | 14,0 - 22,0     | 3,5 - 11,0           | 2.227      | 1.452      |
|                | 65 - 350  | 65           | 350              | 53 - 67       | 14 - 31          | 14,0 - 20,0     | 3,5 - 11,0           | 2.325      | 1.479      |
|                | 75 - 250  | 75           | 250              | 53 - 76       | 14 - 49          | 14,0 - 26,0     | 3,5 - 11,0           | 2.269      | 1.460      |
|                | 75 - 280  | 75           | 280              | 53 - 76       | 14 - 49          | 14,0 - 26,0     | 3,5 - 11,0           | 2.401      | 1.496      |
|                | 75 - 300  | 75           | 300              | 53 - 75       | 14 - 44          | 14,0 - 24,0     | 3,5 - 11,0           | 2.489      | 1.520      |
|                | 75 - 330  | 75           | 330              | 53 - 75       | 14 - 44          | 14,0 - 22,0     | 3,5 - 11,0           | 2.622      | 1.555      |
|                | 85 - 220  | 85           | 220              | 55 - 87       | 17 - 64          | 16,0 - 28,0     | 3,5 - 11,0           | 2.412      | 1.538      |
|                | 75 - 350  | 75           | 350              | 53 - 75       | 14 - 39          | 14,0 - 22,0     | 3,5 - 11,0           | 2.781      | 1.650      |
|                | 85 - 270  | 85           | 270              | 53 - 83       | 14 - 60          | 14,0 - 28,0     | 3,5 - 11,0           | 2.767      | 1.672      |
| <b>T42</b>     | 85 - 300  | 85           | 300              | 53 - 83       | 14 - 60          | 14,0 - 28,0     | 3,5 - 11,0           | 2.937      | 1.720      |
|                | 85 - 320  | 85           | 320              | 53 - 83       | 14 - 55          | 14,0 - 26,0     | 3,5 - 11,0           | 3.051      | 1.752      |
|                | 90 - 260  | 90           | 260              | 55 - 90       | 17 - 73          | 16,0 - 30,0     | 3,5 - 11,0           | 2.889      | 1.718      |
|                | 90 - 280  | 90           | 280              | 55 - 88       | 17 - 71          | 16,0 - 30,0     | 3,5 - 11,0           | 3.016      | 1.775      |
|                | 90 - 300  | 90           | 300              | 55 - 86       | 17 - 69          | 16,0 - 30,0     | 3,5 - 11,0           | 3.144      | 1.792      |
|                | 75 - 400  | 75           | 400              | 53 - 71       | 14 - 33          | 14,0 - 20,0     | 3,5 - 11,0           | 3.577      | 2.309      |
| <b>T51</b>     | 75 - 420  | 75           | 420              | 53 - 71       | 14 - 33          | 14,0 - 20,0     | 3,5 - 11,0           | 3.666      | 2.349      |
|                | 85 - 350  | 85           | 350              | 53 - 83       | 14 - 55          | 14,0 - 26,0     | 3,5 - 11,0           | 3.796      | 2.325      |
|                | 85 - 370  | 85           | 370              | 53 - 80       | 14 - 52          | 14,0 - 26,0     | 3,5 - 11,0           | 3.910      | 2.378      |
|                | 90 - 330  | 90           | 330              | 55 - 86       | 17 - 69          | 16,0 - 30,0     | 3,5 - 11,0           | 3.909      | 2.334      |
|                | 90 - 350  | 90           | 350              | 55 - 87       | 17 - 64          | 16,0 - 28,0     | 3,5 - 11,0           | 4.037      | 2.389      |
|                | 85 - 400  | 85           | 400              | 53 - 76       | 14 - 49          | 14,0 - 26,0     | 3,5 - 11,0           | 4.040      | 2.443      |
|                | 85 - 450  | 85           | 450              | 53 - 76       | 14 - 44          | 14,0 - 24,0     | 3,5 - 11,0           | 4.324      | 2.592      |
|                | 90 - 370  | 90           | 370              | 55 - 83       | 17 - 60          | 16,0 - 28,0     | 3,5 - 11,0           | 4.124      | 2.449      |
| <b>T61</b>     | 90 - 390  | 90           | 390              | 55 - 83       | 17 - 55          | 16,0 - 26,0     | 3,5 - 11,0           | 4.251      | 2.512      |
|                | 90 - 420  | 90           | 420              | 55 - 83       | 17 - 55          | 16,0 - 26,0     | 3,5 - 11,0           | 4.442      | 2.615      |
|                | 90 - 450  | 90           | 450              | 55 - 80       | 17 - 52          | 16,0 - 26,0     | 3,5 - 11,0           | 4.633      | 2.714      |
|                | 100 - 300 | 100          | 300              | 55 - 90       | 17 - 73          | 16,0 - 30,0     | 3,5 - 11,0           | 4.126      | 2.462      |
|                | 100 - 330 | 100          | 330              | 55 - 90       | 17 - 73          | 16,0 - 30,0     | 3,5 - 11,0           | 4.362      | 2.531      |
|                | 100 - 350 | 100          | 350              | 55 - 86       | 17 - 69          | 16,0 - 30,0     | 3,5 - 11,0           | 4.519      | 2.577      |

**Dimensions**

| RAINSTAR Model | Height mm | Width mm | Length with trolley mm | Length less trolley mm | Clearance mm | Tyres        | Track width mm |
|----------------|-----------|----------|------------------------|------------------------|--------------|--------------|----------------|
| <b>T32</b>     | 2.600     | 1.950    | 5.370                  | 3.720                  | 260          | 195/70 R14   | 1.500 - 2.000  |
| <b>T42</b>     | 2.850     | 1.950    | 5.370                  | 3.720                  | 275          | 205 R 14 C   | 1.500 - 2.000  |
| <b>T51</b>     | 3.140     | 2.298    | 5.306                  | 4.045                  | 275          | 205/R 14C    | 1.500 - 2.000  |
| <b>T61</b>     | 3.180     | 2.298    | 5.306                  | 4.045                  | 310          | 10,5/75-15,3 | 1.500 - 2.000  |

**Coupling height (mm)**

| 220 | 500 | 367 |
|-----|-----|-----|
| 240 | 520 | 373 |
| 235 | 510 | 382 |
| 270 | 545 | 417 |

**RAINSTAR E**
**Specification**

| RAINSTAR Model | Type      | PE-pipe Ø mm | PE-pipe Length m | Strip width m | Consumption m³/h | Nozzle sizes mm | Connection press bar | Weight kg  |            |
|----------------|-----------|--------------|------------------|---------------|------------------|-----------------|----------------------|------------|------------|
|                |           |              |                  |               |                  |                 |                      | with water | less water |
| <b>E11</b>     | 90 - 480  | 90           | 480              | 54 - 75       | 17 - 44          | 16,0 - 24,0     | 4,5 - 11,0           | 5.595      | 3.548      |
|                | 100 - 350 | 100          | 350              | 58 - 94       | 22 - 77          | 18,0 - 30,0     | 4,5 - 11,0           | 5.290      | 3.307      |
|                | 100 - 380 | 100          | 380              | 58 - 90       | 22 - 73          | 18,0 - 30,0     | 4,5 - 11,0           | 5.526      | 3.391      |
|                | 100 - 400 | 100          | 400              | 58 - 90       | 22 - 69          | 18,0 - 30,0     | 4,5 - 11,0           | 5.683      | 3.515      |
|                | 110 - 300 | 110          | 300              | 80 - 112      | 41 - 112         | 25,0 - 37,5     | 4,5 - 11,0           | 5.392      | 3.350      |
|                | 110 - 330 | 110          | 330              | 77 - 109      | 35 - 105         | 20,0 - 35,0     | 4,5 - 11,0           | 5.677      | 3.450      |
|                | 110 - 350 | 110          | 350              | 75 - 106      | 33 - 98          | 22,5 - 35,0     | 4,5 - 11,0           | 5.867      | 3.506      |
| <b>E21</b>     | 100 - 430 | 100          | 430              | 58 - 87       | 22 - 64          | 18,0 - 28,0     | 4,5 - 11,0           | 6.156      | 3.878      |
|                | 100 - 450 | 100          | 450              | 54 - 83       | 17 - 55          | 16,0 - 26,0     | 4,5 - 11,0           | 6.313      | 3.940      |
|                | 110 - 350 | 110          | 350              | 75 - 105      | 33 - 92          | 22,5 - 35,0     | 4,5 - 11,0           | 6.105      | 3.744      |
|                | 110 - 380 | 110          | 380              | 75 - 105      | 33 - 92          | 22,5 - 35,0     | 4,5 - 11,0           | 6.390      | 3.855      |
|                | 110 - 400 | 110          | 400              | 75 - 103      | 33 - 92          | 22,5 - 35,0     | 4,5 - 11,0           | 6.580      | 3.946      |
| <b>E31</b>     | 110 - 420 | 110          | 420              | 75 - 102      | 33 - 84          | 22,5 - 35,0     | 4,5 - 11,0           | 6.770      | 4.027      |
|                | 120 - 300 | 120          | 300              | 80 - 115      | 41 - 118         | 25,0 - 37,5     | 4,5 - 11,0           | 6.115      | 3.813      |
|                | 100 - 480 | 100          | 480              | 54 - 83       | 17 - 55          | 16,0 - 26,0     | 4,5 - 11,0           | 6.648      | 4.219      |
|                | 100 - 500 | 100          | 500              | 54 - 83       | 17 - 55          | 16,0 - 26,0     | 4,5 - 11,0           | 6.805      | 4.275      |
|                | 100 - 520 | 100          | 520              | 54 - 80       | 17 - 52          | 16,0 - 26,0     | 4,5 - 11,0           | 6.962      | 4.391      |
| <b>E41</b>     | 110 - 450 | 110          | 450              | 73 - 100      | 28 - 80          | 20,0 - 32,5     | 4,5 - 11,0           | 7.154      | 4.334      |
|                | 110 - 470 | 110          | 470              | 73 - 99       | 28 - 80          | 20,0 - 32,5     | 4,5 - 11,0           | 7.345      | 4.399      |
|                | 110 - 490 | 110          | 490              | 73 - 97       | 28 - 78          | 18,0 - 30,0     | 4,5 - 11,0           | 7.535      | 4.486      |
|                | 125 - 310 | 125          | 310              | 80 - 115      | 41 - 118         | 25,0 - 37,5     | 4,5 - 11,0           | 6.682      | 4.183      |
|                | 125 - 350 | 125          | 350              | 80 - 114      | 41 - 112         | 25,0 - 37,5     | 4,5 - 11,0           | 7.173      | 4.351      |
| <b>E51</b>     | 100 - 550 | 100          | 550              | 54 - 80       | 17 - 52          | 16,0 - 26,0     | 4,5 - 11,0           | 7.787      | 5.093      |
|                | 100 - 590 | 100          | 590              | 54 - 78       | 17 - 50          | 16,0 - 26,0     | 4,5 - 11,0           | 8.101      | 5.248      |
|                | 110 - 500 | 110          | 500              | 58 - 86       | 22 - 69          | 18,0 - 30,0     | 4,5 - 11,0           | 8.219      | 5.215      |
|                | 110 - 520 | 110          | 520              | 66 - 87       | 28 - 69          | 20,0 - 30,0     | 4,5 - 11,0           | 8.409      | 5.284      |
|                | 110 - 550 | 110          | 550              | 66 - 87       | 28 - 69          | 20,0 - 28,0     | 4,5 - 11,0           | 8.694      | 5.455      |
| <b>E51</b>     | 120 - 420 | 120          | 420              | 75 - 109      | 33 - 103         | 22,5 - 35,0     | 4,5 - 11,0           | 8.217      | 5.045      |
|                | 120 - 450 | 120          | 450              | 75 - 108      | 33 - 98          | 22,5 - 35,0     | 4,5 - 11,0           | 8.557      | 5.158      |
|                | 125 - 370 | 125          | 370              | 80 - 115      | 41 - 118         | 25,0 - 37,5     | 4,5 - 11,0           | 8.008      | 4.888      |
|                | 125 - 400 | 125          | 400              | 80 - 115      | 41 - 118         | 25,0 - 37,5     | 4,5 - 11,0           | 8.376      | 5.003      |
|                | 140 - 340 | 140          | 340              | 80 - 118      | 41 - 124         | 25,0 - 37,5     | 4,5 - 11,0           | 8.855      | 5.302      |
| <b>E51</b>     | 110 - 590 | 110          | 590              | 58 - 83       | 22 - 65          | 18,0 - 30,0     | 4,5 - 11,0           | 8.982      | 5.552      |
|                | 110 - 620 | 110          | 620              | 58 - 80       | 22 - 52          | 18,0 - 26,0     | 4,5 - 11,0           | 9.267      | 5.698      |
|                | 110 - 650 | 110          | 650              | 58 - 80       | 22 - 52          | 18,0 - 26,0     | 4,5 - 11,0           | 9.552      | 5.892      |
|                | 120 - 530 | 120          | 530              | 75 - 103      | 33 - 92          | 22,5 - 35,0     | 4,5 - 11,0           | 9.369      | 5.532      |
|                | 120 - 550 | 120          | 550              | 75 - 103      | 33 - 88          | 22,5 - 32,5     | 4,5 - 11,0           | 9.595      | 5.705      |
|                | 120 - 570 | 120          | 570              | 75 - 103      | 33 - 85          | 22,5 - 32,5     | 4,5 - 11,0           | 9.822      | 5.837      |
|                | 120 - 600 | 120          | 600              | 76 - 102      | 33 - 80          | 22,5 - 32,5     | 4,5 - 11,0           | 10.160     | 6.050      |
|                | 125 - 450 | 125          | 450              | 80 - 112      | 41 - 112         | 25,0 - 37,5     | 4,5 - 11,0           | 8.897      | 5.161      |
|                | 125 - 500 | 125          | 500              | 75 - 108      | 33 - 98          | 22,5 - 35,0     | 4,5 - 11,0           | 9.511      | 5.480      |
|                | 140 - 400 | 140          | 400              | 80 - 118      | 41 - 124         | 25,0 - 37,5     | 4,5 - 11,0           | 9.533      | 5.599      |

**RAINSTAR E**
**Specification**

| RAINSTAR Model    | Type      | PE-pipe Ø mm | PE-pipe Length m | Strip width m | Consumption m³/h | Nozzle sizes mm | Connection press bar | Weight kg  |            |
|-------------------|-----------|--------------|------------------|---------------|------------------|-----------------|----------------------|------------|------------|
|                   |           |              |                  |               |                  |                 |                      | with water | less water |
| <b>E51 XL 4W</b>  | 110 - 670 | 110          | 670              | 65 - 92       | 25 - 55          | 18 - 26         | 5 - 11               | 10.617     | 6.869      |
|                   | 110 - 700 | 110          | 700              | 65 - 92       | 25 - 55          | 18 - 26         | 5 - 11               | 10.902     | 7.073      |
|                   | 120 - 630 | 120          | 630              | 75 - 98       | 33 - 72          | 22 - 32,5       | 5 - 11               | 11.375     | 7.055      |
|                   | 120 - 650 | 120          | 650              | 75 - 98       | 33 - 72          | 22 - 32,5       | 5 - 11               | 11.601     | 7.144      |
|                   | 125 - 560 | 125          | 560              | 80 - 104      | 40 - 88          | 25 - 35         | 5 - 11               | 11.122     | 6.746      |
|                   | 120 - 580 | 125          | 580              | 80 - 104      | 40 - 88          | 25 - 35         | 5 - 11               | 11.368     | 7.144      |
|                   | 125 - 600 | 125          | 600              | 80 - 104      | 40 - 88          | 25 - 35         | 5 - 11               | 11.613     | 7.082      |
|                   | 125 - 620 | 125          | 620              | 80 - 104      | 40 - 88          | 25 - 35         | 5 - 11               | 11.859     | 7.178      |
|                   | 140 - 430 | 140          | 430              | 80 - 114      | 40 - 110         | 25 - 37,5       | 5 - 11               | 10.869     | 6.555      |
|                   | 140 - 460 | 140          | 460              | 80 - 114      | 40 - 110         | 25 - 37,5       | 5 - 11               | 11.331     | 6.715      |
| <b>E51 XL 4WB</b> | 110 - 670 | 110          | 670              | 65 - 92       | 25 - 55          | 18 - 26         | 5 - 11               | 10.597     | 6.849      |
|                   | 110 - 700 | 110          | 700              | 65 - 92       | 25 - 55          | 18 - 26         | 5 - 11               | 10.882     | 7.053      |
|                   | 120 - 630 | 120          | 630              | 75 - 98       | 33 - 72          | 22 - 32,5       | 5 - 11               | 11.355     | 7.035      |
|                   | 120 - 650 | 120          | 650              | 75 - 98       | 33 - 72          | 22 - 32,5       | 5 - 11               | 11.581     | 7.124      |
|                   | 125 - 560 | 125          | 560              | 80 - 104      | 40 - 88          | 25 - 35         | 5 - 11               | 11.102     | 6.726      |
|                   | 120 - 580 | 125          | 580              | 80 - 104      | 40 - 88          | 25 - 35         | 5 - 11               | 11.348     | 6.883      |
|                   | 125 - 600 | 125          | 600              | 80 - 104      | 40 - 88          | 25 - 35         | 5 - 11               | 11.593     | 7.062      |
|                   | 125 - 620 | 125          | 620              | 80 - 104      | 40 - 88          | 25 - 35         | 5 - 11               | 11.839     | 7.158      |
|                   | 140 - 430 | 140          | 430              | 80 - 114      | 40 - 110         | 25 - 37,5       | 5 - 11               | 10.849     | 6.535      |
|                   | 140 - 460 | 140          | 460              | 80 - 114      | 40 - 110         | 25 - 37,5       | 5 - 11               | 11.311     | 6.695      |
| <b>E55 L</b>      | 110 - 700 | 110          | 700              | 65 - 82       | 25 - 55          | 18 - 26         | 5 - 11               | 10.820     | 6.993      |
|                   | 120 - 650 | 120          | 650              | 75 - 98       | 33 - 72          | 22 - 32,5       | 5 - 11               | 11.521     | 7.064      |
|                   | 125 - 620 | 125          | 620              | 80 - 103      | 40 - 88          | 25 - 35         | 5 - 11               | 11.779     | 7.097      |
|                   | 140 - 460 | 140          | 460              | 80 - 115      | 40 - 110         | 25 - 37,5       | 5 - 11               | 11.251     | 6.727      |
|                   | 125 - 680 | 125          | 680              | 70 - 100      | 30 - 70          | 20 - 30         | 5 - 11               | 12.800     | 8.090      |
| <b>E55 XL</b>     | 125 - 710 | 125          | 710              | 70 - 100      | 30 - 70          | 20 - 30         | 5 - 11               | 13.160     | 8.245      |
|                   | 125 - 740 | 125          | 740              | 70 - 100      | 30 - 70          | 20 - 30         | 5 - 11               | 13.530     | 8.400      |
|                   | 140 - 500 | 140          | 500              | 80 - 110      | 30 - 110         | 20 - 37,5       | 5 - 11               | 12.270     | 7.485      |
|                   | 140 - 530 | 140          | 530              | 80 - 110      | 30 - 110         | 20 - 37,5       | 5 - 11               | 12.730     | 7.655      |
|                   | 140 - 560 | 140          | 560              | 80 - 110      | 30 - 110         | 20 - 37,5       | 5 - 11               | 13.190     | 7.830      |

**Dimensions**

| RAINSTAR Model        | Height mm | Width mm | Length with trolley mm | Length less trolley mm | Clearance mm | Tyres        | Track width mm |
|-----------------------|-----------|----------|------------------------|------------------------|--------------|--------------|----------------|
| <b>E11</b>            | 3.480     | 2.530    | 7.600                  | 5.450                  | 340          | 11,5/80-15,3 | 1.800 - 2.250  |
| <b>E21</b>            | 3.480     | 2.560    | 7.730                  | 5.580                  | 340          | 11,5/80-15,3 | 1.800 - 2.250  |
| <b>E31</b>            | 3.530     | 2.560    | 7.730                  | 5.580                  | 340          | 12,5/80-15,3 | 1.800 - 2.250  |
| <b>E41</b>            | 3.730     | 2.670    | 8.120                  | 6.160                  | 340          | 12,5/80-15,3 | 1.800 - 2.250  |
| <b>E51</b>            | 4.070     | 2.670    | 8.200                  | 6.230                  | 360          | 12,5/80-15,3 | 1.800 - 2.250  |
| <b>E51 XL 4W</b>      | 4.420     | 2.712    | 8.020                  | 5.940                  | 640          | 10,0/75-15,3 | 1.800 - 2.250  |
| <b>E51 XL 4WB</b>     | 4.290     | 3.018    | 8.590                  | 6.250                  | 440          | 12,5/80-15,3 | 2.600          |
| <b>E55 L &amp; XL</b> | 4.030     | 3.160    | 8.470                  | 5.260                  | 270          | 12,5/80-15,3 | 2.840          |

**Coupling height (mm)**

| 223 | 498 | 500   |
|-----|-----|-------|
| 229 | 504 | 540   |
| 235 | 510 | 540   |
| 270 | 545 | 560   |
| 340 | 620 | 590   |
| 570 | 850 | 1.020 |
| 520 | 790 | 1.020 |
| 700 | -   | -     |

PRODUCTS FROM OUR IRRIGATION PROGRAM



SYSTEM 9000



Your dealer

**Röhren- und Pumpenwerk BAUER GmbH**

8570 Voitsberg/Austria

**T** +43 3142 200-0

**F** +43 3142 200-320/-340

**M** sales@bauer-at.com

**W** www.bauer-at.com

